

STRATO-APEX

PRE 1370



Precision meets speed

Mitutoyo

STRATO-Apex: Simply more.

The challenges for measurement equipment are rising. Products are continuously improving – as a result the lifetime of products is increasing while the energy consumption of products is reduced. Additionally, the throughput of production is driven up. All these facts must be taken into account for your measuring equipment. With the STRATO-Apex CMM, Mitutoyo offers you the opportunity to match both: precision and velocity.

Because you need more!

More precision.

The STRATO-Apex CMM is equipped with special glass scales originally designed for our high-end CMM series "LEGEX". These scales lead to a resolution of 20 nanometer – that's 0,00002 mm! The scales are made from Zeroglass which has the positive effect that its length is not changing with temperature. These scales lead to a basic accuracy of 0.9 μm and enable you to reach even very small tolerances.

More efficiency.

The new controller UC400 provides a high scanning speed up to 100mm/s. Additionally, STRATO-Apex is ready for multisensor measurements: single points in touch-trigger mode, scanning, laser scanning with the new SurfaceMeasure line laser probe, vision system QV-P. Almost all kinds of measurement tasks can be handled with the STRATO-Apex – at high accuracy.

More strength.

The STRATO-Apex contains special features to reach your quality goals. Besides a **thermal compensation unit** it provides an **active vibration damping system** to eliminate the environmental impacts of your measuring tasks – **as standard!**



STRATO-Apex

More tolerance.

The high accuracy of the STRATO-Apex reduces the measurement uncertainty. This leads to more tolerance left for whom it belongs – your production!

Standard CMM

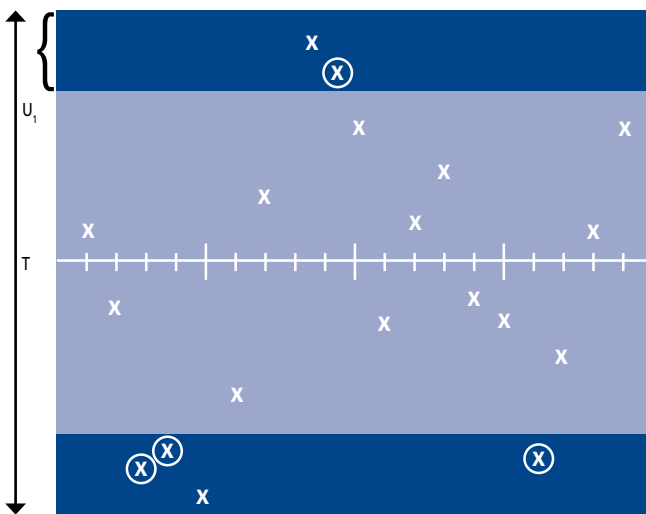

STRATO-Apex

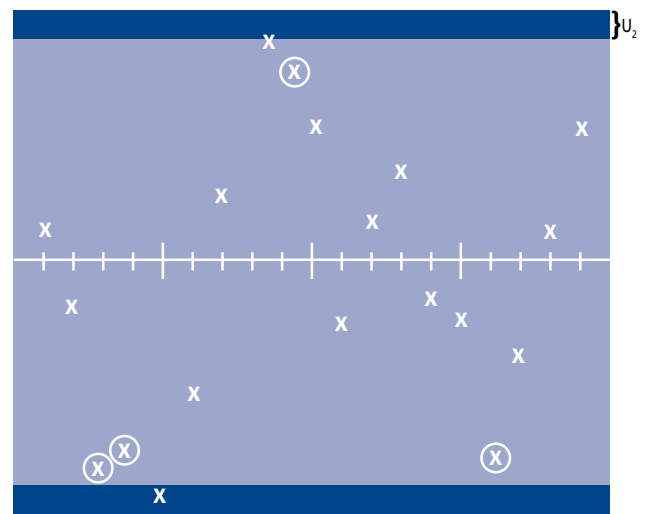

The tolerance zone T is decreasing with measurement uncertainty U. Having a smaller uncertainty like the Strato-Apex, allows you to judge more products as "Go".

With STRATO-Apex, Mitutoyo offers you:

- a higher acceptance of your results
- more trust into your products
- more confidence into your production
- less rework or parts identified as scrap
- to reach new markets with high precision parts.



Vibration-damping unit with auto-leveling air springs



Probe systems – for the right touch.

Measuring probe holder heads

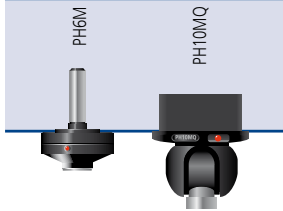

Touch-trigger probes

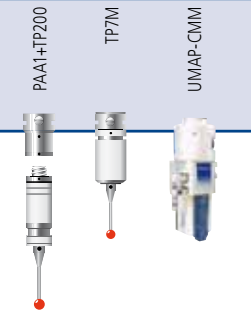

Dynamic measuring probes/systems

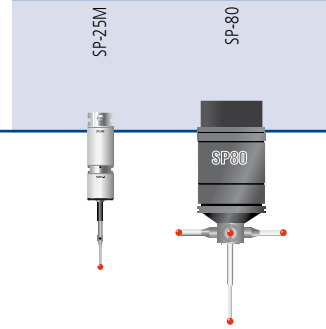

Optical measuring heads



Probe change system

MRS-ACR3



Mitutoyo aims to offer you the measurement system that fits best to your measurement task:

- tactile scanning probes like SP25M or SP80 for fast measurements at a high point density,
- high precision touch-trigger probes with tips down to 0.3 mm even for the smallest features,
- vision systems for fast 2.5D measurements,
- Laser scanner for inspection and reverse engineering,
- automatic changing racks for flexible multi sensor measurements reducing the downtime to a minimum.



MCOSMOS – The modular software for all kinds of measurement

- › Organize your measurement programs on the network, add pictures of workpiece and fixture positions.
- › Add commands and instructions to guide the operator.
- › Create individual reports meeting your customers needs.
- › Archive your results in formats like pdf, xls, HTML or many other.
- › SPC with MeasurLink or export to QS-Stat or CAQ-systems like Böhme & Weihs.
- › Export geometric elements to CAD systems.
- › Revision Management for authorised usage of validated part programs **as standard**. Meet the requirements of FDA title 21 CFR Part 11 without extra costs.



Mitutoyo offers the following packages:

- MCOSMOS-1:** The Basic software package for prismatic workpieces.
Easy programming of geometrical elements by joystick control or input of nominal values. Special features like clearance height or automatic element recognition helps you to prevent collisions and to reduce the programming time.
- MCOSMOS-2:** The CAD package for freeform surfaces and geometric elements.
Why typing-in parameters when all features are already available in the CAD model? CAD based programming offers you the way to cut down the programming time once more. GD&T entities inside the CAD file helps you to measure all essential features.
- MCOSMOS-3:** The Full package.
MCOSMOS-3 provides additional tools for measurement evaluation of contours in 2D or on the CAD model.
- VIRTUAL MCOSMOS:** All three packages are available as an offline version. Programming in offline mode keeps the CMM free for real measurements. Since you only need the CAD file for programming, you don't even have to wait for the first part being produced. Many CAD interfaces like CATIA or PRO/E are available. That enables you to import your CAD models without any data getting lost. VIRTUAL MCOSMOS-2 can be ordered as multi-license package for 5 and 10 users.

Additional software packages to meet your needs:

MeasurLink:	SPC software with certified AQDEF interface. Allows you to collect data from different vendors and devices. Its database offers you to collect data worldwide, analyse your process and create individual reports.
Correct Plus:	Software for automatic feedback of correction data to connecting NC machining centres with any measurement equipment, e.g. CMM, small tools, transducers or analogue probes.
Gearpak:	Turn your CMM into a gear measurement device! Extend your capabilities, measure gears, worm gears, helical gears. Just input the gear parameters - the rest will be done by Gearpak: measurement strategy, path generation, probe changes, and of course the measurement report of your gear.
Roundpak CMM:	Special evaluation tool for scanning measurements typically known of form measuring instruments. Topographic views and evaluation of form and position deviations.
Geo_EDM:	Capture the offset data of your EDM tools and workpieces. Geo_EDM is the solution for measuring the typical geometries in the EDM field, determining its offset value and transfer them into special EDM formats. Lots of vendor for mats like Charmilles, System 3R, Ingersoll and Mitsubishi are supported.

Let's talk about some details.



STRATO-Apex 776



STRATO-Apex 9106

Specifications

Item		STRATO-Apex 776	STRATO-Apex 7106	STRATO-Apex 9106	STRATO-Apex 9166
Measuring range	X	705 mm		905 mm	
	Y	705 mm	1005 mm		1605 mm
	Z	605 mm			
Guide method		Air bearings on all axes (static pressure air bearings)			
Drive speed	CNC mode	Drive speed: From 8 to 300 mm/s for each axis (maximum combined speed: 519 mm/s)			
		Measuring speed 1 – 3 mm/s			
	J/S mode	Drive speed 0 – 80 mm/s Measuring speed 0 – 3 mm/s Fine-positioning speed 0.05 mm/s			
Drive acceleration		1.500 mm/s ² for each axis (maximum combined acceleration: 2.598 mm/s ²)			
Measuring method		Linear encoder			
Resolution		0.00002 mm			
Work table	Material	Granite			
	Size (table surface)	880 x 1420 mm	880 x 1720 mm	1080 x 1720 mm	1080 x 2320 mm
	Tapped inserts	M8 x 1.25 mm			
Workpiece	Maximum height	770 mm			
	Maximum mass	500 kg	800 kg	800 kg	1200 kg
Machine mass (includes the vibration-damping platform and controller, but not workpiece)		1895 kg	2180 kg	2410 kg	3085 kg
Power supply specifications (including the probe option interface)		Power supply voltage: AC100-120/200-240 V ± 10%; power supply capacity: 700 VA (of which 170 VA is used for the optional probe interface)			
Air supply	Pressure	0.4 MPa			
	Consumption	60 L/min under normal conditions (air source: At least 120 L/min)			
Guaranteed accuracy temperature environment	Temperature range		19 – 21 °C		
	Temperature change	Per hour	1.0 K		
		Per 24 hours	2.0 K		
Temperature gradient		vertical/horizontal 1.0 K/m			

Indicating error

unit: μm

	Probe used	MPE _E
ISO 10360-2: 2001	SP25M/MPP-310Q	0.9+0,25/100
	TP200	1.4+0,25/100 (for model 776/7106) 1.5+0,25/100 (for model 9106/9166)

Probing error

unit: μm

	Probe used	MPE _P
ISO 10360-2: 2001	SP25M	0.9
	MPP-310Q	0.9
	TP200	1.8

Scanning probing error

unit: μm

	Probe used	MPE _{THP}
ISO 10360-4: 2001	SP25M	1.8 (MPT _{THP} = 45 s)
	MPP-310Q	2.0 (MPT _{THP} = 70 s)

Specifications

Dimensions

unit: mm

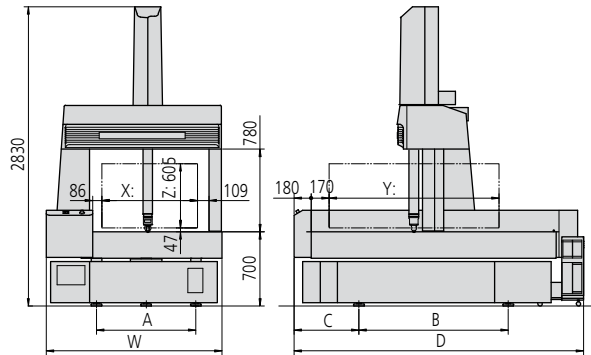

Item	STRATO-Apex 776	STRATO-Apex 7106	STRATO-Apex 9106	STRATO-Apex 9166
A	740			940
B	700		1000	1410
C	540			632.5
D	1860		2160	2760
E		1460		1660
F		3210		3410
G			520	
H	4160		4460	5060

Installation floor space

unit: mm

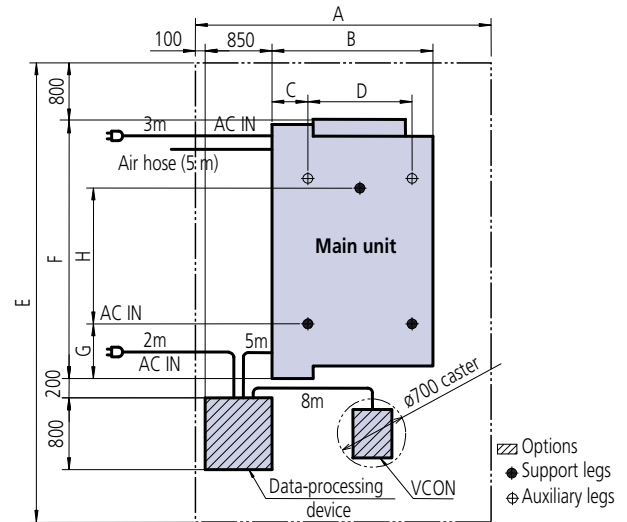

Tapped insert positions in the table surface

unit: mm

STRATO-Apex 776

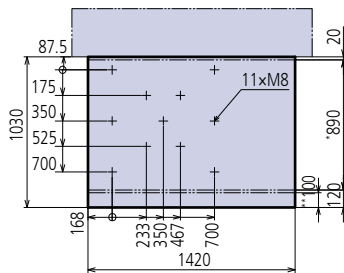

STRATO-Apex 7106

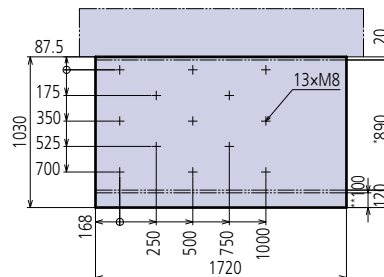

STRATO-Apex 9106

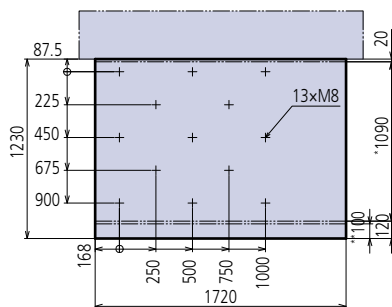

STRATO-Apex 9166

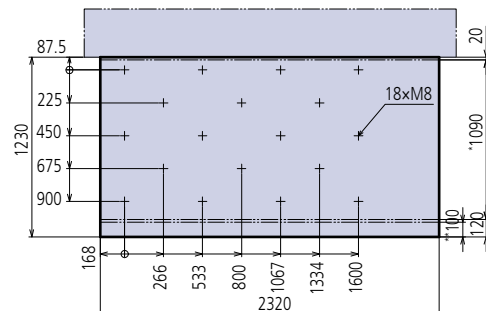



Example of a system for a pallet loading system

CMM > software > probe systems > probe changers > styli
 > rotary tables > loading systems > fixtures > cabins and enclosures
 > calibration > training > service > consultation
 Mitutoyo: Experience and innovation.

Ask for further individual brochures of Mitutoyo products:



MCOSMOS



Probe systems



Styli systems

Further information can be found on our product lounge
 Coordinate Measuring Machines: www.mitutoyo.eu

- Coordinate Measuring Machines
- Vision Measuring Systems
- Form Measurement
- Optical Measuring
- Sensor Systems
- Test Equipment and Seismometers
- Digital Scale and DRO Systems
- Small Tool Instruments and Data Management

Mitutoyo Nederland b.v.
 Storkstraat 40
 3905 KX Veenendaal
 T 0031 318 534911
 F 0031 318 534811
sales@mitutoyo.nl
www.mitutoyo.nl



Note: All information about our products in this printed material, particularly the illustrations, drawings, measurement and performance specifications, as well as other technical specifications, are to be interpreted as approximate average values. In this respect, changes in construction, technical specification, measures and weights remain reserved. Our specified standards, similar technical regulations as well as the technical specifications, descriptions and illustrations of products are accurate on the date of printing. Furthermore, our general terms of business in the currently applicable revision are binding. Only the offers we make are definitive.