

# ABS LINEAR SCALE AT500-S/H

## ABSOLUTE Linear Encoder for NC Control

CATALOG No. E4265-539



The slim-type AT500 series can contribute to the enhanced performance of NC machine tools.

**AT500-S:** Compatible with both vibration/impact resistance and temperature characteristics

**AT500-H:** Excellent in temperature characteristics and reproducibility of measuring accuracy

## Overview

**This Absolute Linear Scale has achieved the best-in-class response speed of 150m/min.**

- Optimized for high-speed control of linear motors, etc.

### Implementation of High-rigidity [AT500-S Series]

- Has achieved the best-in-class vibration resistance of 20G and impact resistance of 35G in Absolute scale units.
- Available in safety for high-accuracy machining, high-speed machining, and heavy cutting due to the accelerated rotation of the main spindle.
- Has improved in stability of the datum point of expansion with respect to temperature variations.
- Optimized for long-time machining of molds, complicated aluminum machining, and twin servo system control.

### Implementation of High-accuracy [AT500-H Series]

- Measuring accuracy:  $2+2L/1000$  ( $\mu\text{m}$ )
- Has improved in accuracy reproducibility and temperature characteristics and can select the datum point position of expansion from "Center/Right end/Left end" on the effective scale (can optimize the system according to temperature variations).
- Appropriate for use with an NC lathe or an electric discharge machine (contributing to the improvement of machining accuracy).

## Structural Features

**The scale is compatible with both vibration/impact resistance and temperature characteristics. [AT500-S series]**

The combination of an optimized detector head structure and a scale main unit that employs multi-point elastic fixing with various analysis technologies has attained excellent vibration/impact resistance and temperature characteristics.

1. Example of detector head structure analysis (FEM analysis)

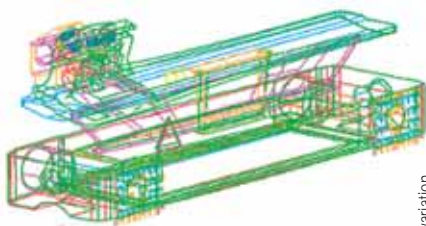

2. Vibration resistance characteristics

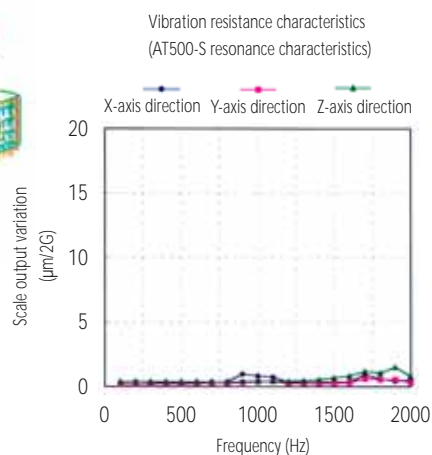

3. Example of impact resistance characteristics

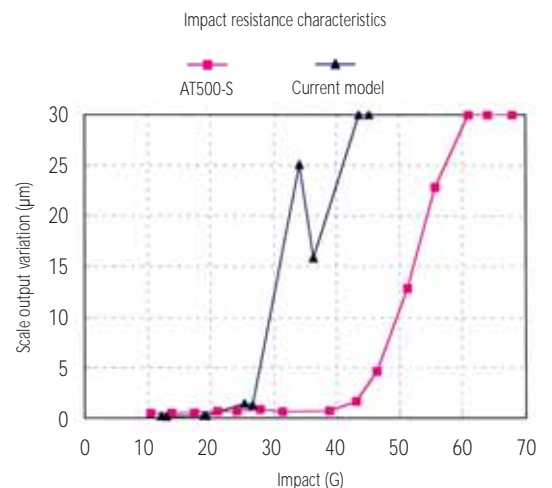

**Mitutoyo**

## Excellent Temperature Characteristics and Improved Accuracy Reproducibility [AT500-H Series]

This series completely eliminates friction on the scale main unit, and employs an elastic fixing mechanism that has the "parallel leaf spring" function on both unit ends.

It has achieved excellent temperature characteristics and improved accuracy reproducibility.

### 4. Structure image

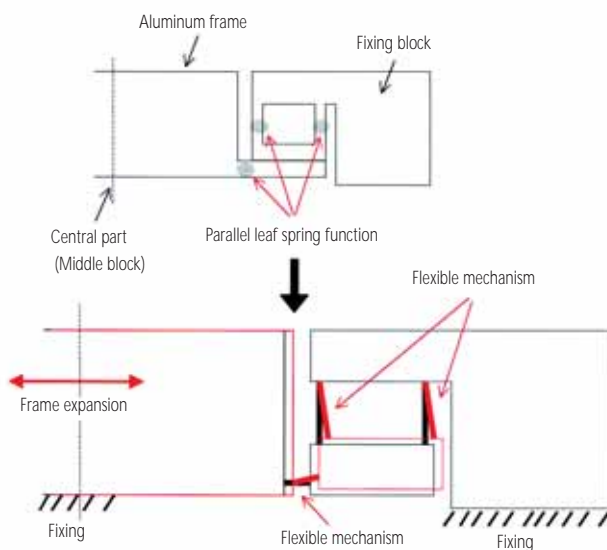

### 5. Temperature characteristics (example)

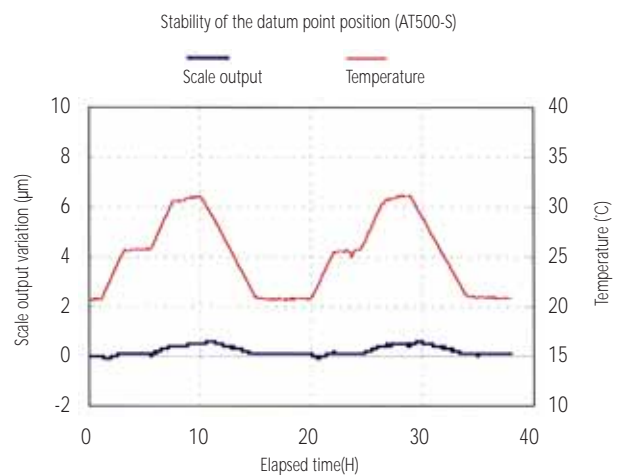

Note: "Datum point position of expansion"  
The linear scale expands and contracts according to temperature variations.  
In this case the origin of mechanical expansion of the scale is defined as "Datum point position".

## Specifications

Item	High-rigidity type	High-accuracy type	
	AT500-SC	AT500-HC	AT500-HL/HR
Mounting method of the scale main unit	Multi-point elastic fixing	3 or 5-point elastic fixing	3 or 4-point elastic fixing
Datum point position of expansion to temperature variations	Center of effective measuring length		End of effective measuring range HL: (+ side end), HR: (- side end)
Effective measuring length	100 to 2200mm	100 to 1000mm	100 to 350mm
Detecting method	Electrostatic capacitance type/photoelectric type composite ABS linear encoder		
Resolution	0.05μm		
Maximum response speed	150m/min (2.5m/s)		
Accuracy (20°C)	3+3L/1000 (μm) L: effective measuring length (mm)	2+2L/1000 (μm) L: effective measuring length (mm)	
Thermal expansion coefficient	8.5±0.5 (10 <sup>-6</sup> /°C)		
Operating temperature/humidity	0 to 45°C, 20% to 80%RH (no condensation)		
Storing temperature/humidity	-20 to 70°C, 20% to 80%RH (no condensation)		
Vibration resistance	20G (55 to 2000Hz)	15G (55 to 2000Hz)	
Impact resistance	35G (1/2Sin 11ms)	20G (1/2Sin 11ms)	
Power supply	DC5V ±5%		
Maximum power consumption	270mA		
Maximum sliding force	4N		
Protection level	Scale main unit: Equivalent to IP53, I/F Box: Equivalent to IP54		
Alarm display function	A scale alarm is indicated with an LED on the I/F Box.		
Air supply orifice	Present		

## Scale Structure

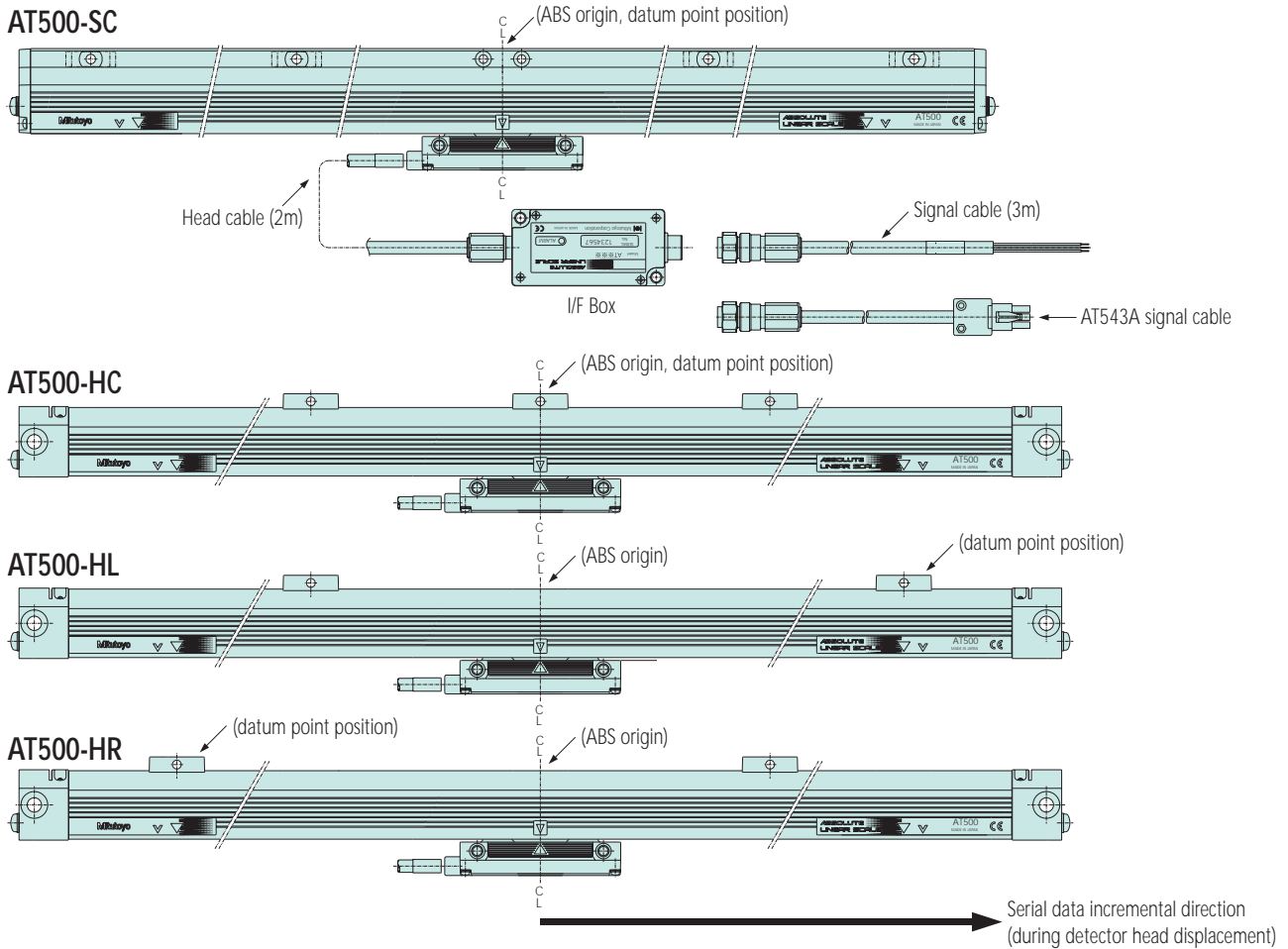

## Scale type

Scale type	Interface
AT553	High-speed serial interface for FANUC LTD.
AT543	High-speed serial interface "MELDAS" for Mitsubishi Electric Corporation
AT543A	High-speed serial interface "MELSERVO" for Mitsubishi Electric Corporation
AT573A	High-speed serial interface "MINAS" for Matsushita Electric Industrial Co., Ltd.
AT503 AT503A	Mitutoyo standard serial interface

\*AT5□3□

Communication method  
Blank: Full-duplex communication  
A: Half-duplex communication

Interface      **AT5**□**3**□ - □□□ - □□

Scale main unit specification

S: High-rigidity type

H: High-accuracy type

Datum point position of expansion on the scale main unit \*

C: Center of effective measuring range

L: End of effective measuring range (+ side end)

R: End of effective measuring range (- side end)

\* L or R is appended to only the high-accuracy type.

**Mitutoyo**

## System Configuration Example/Output Specification

### AT553, AT543, AT573A, AT503, AT503A

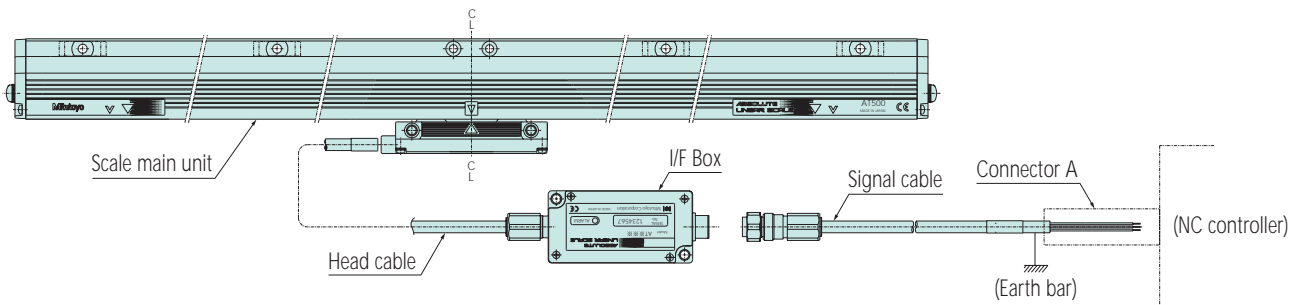

#### [Note]

1. Connector A is to be prepared by the client.
2. Connector A and the grounding bar are to be connected by the client.
3. If a cable is added between the signal cable lead wires and the control unit (e.g. a feedback cable is added), the maximum cable length (the total length of the head cable, signal cable, and feedback cable) is to be 29m.

#### Output specification

AT553/543/503

Wire	Signal	Wire	Signal
Brown/red	+5V	Blue	REQ
White/black	GND	Purple	Phase A
Orange	_SD	Gray	Phase B
Yellow	SD	Shielded	FG
Green	_REQ		

AT573A/503A

Wire	Signal	Wire	Signal
Brown/red	+5V	Blue	RQ/SD
White/black	GND	Purple	Phase A
Orange	NC	Gray	Phase B
Yellow	NC	Shielded	FG
Green	_RQ/_SD		

\* Phase A and phase B are used as test signals. Use the signals while leaving them unconnected.

\* Connect the shield wire to the grounding bar.

### AT543A

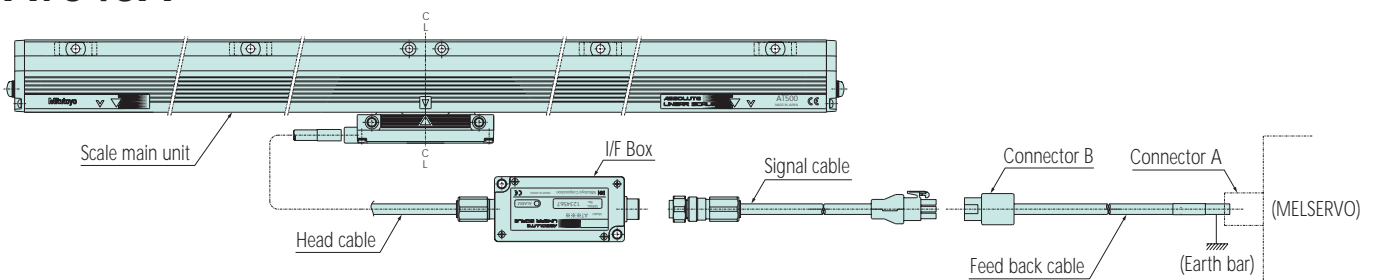

#### [Note]

1. Connectors A and B and feedback cables are to be prepared by the client.
2. Connectors A and B and the grounding bar are to be connected by the client.
3. An encoder cable made by Mitsubishi Electric Corporation can be used for the feedback cable.  
Type: MR-JCCBL□M-H  
A cable length (2, 5, or 10m) is indicated in "□".  
\*The feedback cable configuration differs depending on the system.  
For detailed information, contact Mitsubishi Electric Corporation.
4. If a feedback cable is used, the maximum cable length (the total length of the head cable, signal cable, and feedback cable) is to be 29m.

#### Output specifications

Pin No.	Signal	Pin No.	Signal
1	MR (RQ/DT)	7	P5 (+5V)
2	MRR (*RQ/*DT)	8	LG (0V)
4	(DT)	9	F.G
5	(*DT)	3.6	N.C

\* Applicable connector  
Mini-Universal Mate-N-Lock Connector 9P (female) made by Tyco Electronics AMP  
172161-9 (Housing, black)

# Appearance and Dimensional Drawing

## AT500-SC Series

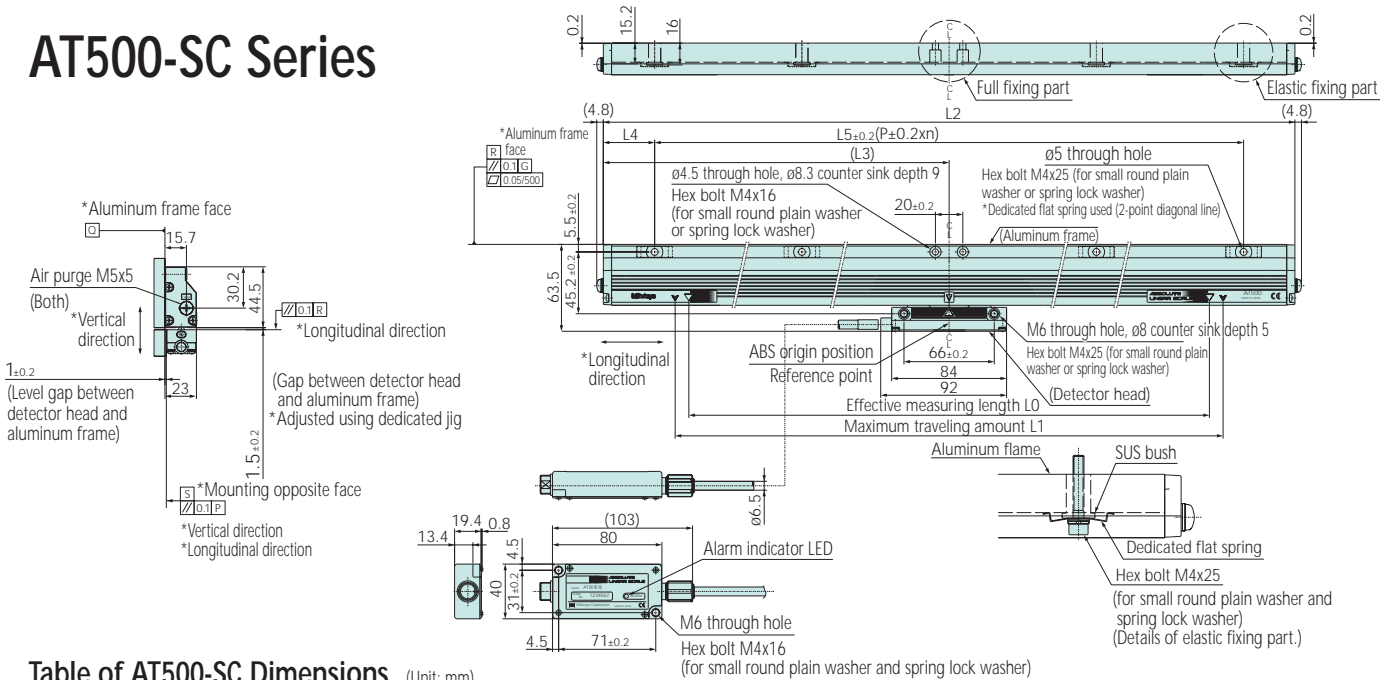

**Table of AT500-SC Dimensions** (Unit: mm)

L0	L1	L2	L3	L4	L5	P	n
100	120	225	112.5	37.5	150	75	2
200	220	325	162.5	37.5	250	125	2
300	320	425	212.5	37.5	350	175	2
400	420	525	262.5	62.5	400	200	2
500	520	625	312.5	62.5	500	125	4
600	620	725	362.5	62.5	600	150	4
700	720	825	412.5	62.5	700	175	4
800	820	925	462.5	62.5	800	200	4
900	920	1025	512.5	62.5	900	150	6
1000	1020	1125	562.5	37.5	1050	175	6
1100	1120	1225	612.5	87.5	1050	175	6
1200	1220	1325	616.5	62.5	1200	200	6
1300	1320	1425	712.5	112.5	1200	150	8
1400	1420	1525	762.5	62.5	1400	175	8
1500	1520	1625	812.5	112.5	1400	175	8
1600	1620	1725	862.5	62.5	1600	200	8
1800	1820	1925	962.5	87.5	1750	175	10
2000	2020	2125	1062.5	62.5	2000	200	10
2200	2220	2325	1162.5	112.5	2100	175	12

[Note]

1. G represents the machine guide.
2. P represents the aluminum frame mounting opposite face. Also, S represents the detector head mounting opposite face.
3. Q and R represent the mounting reference plane of this linear scale.
4. For the values of L0 to L5, P, and n, refer to the following table.

# Appearance and Dimensional Drawing

## AT500-HL/HR Series

Dimensional drawing of AT500-HL

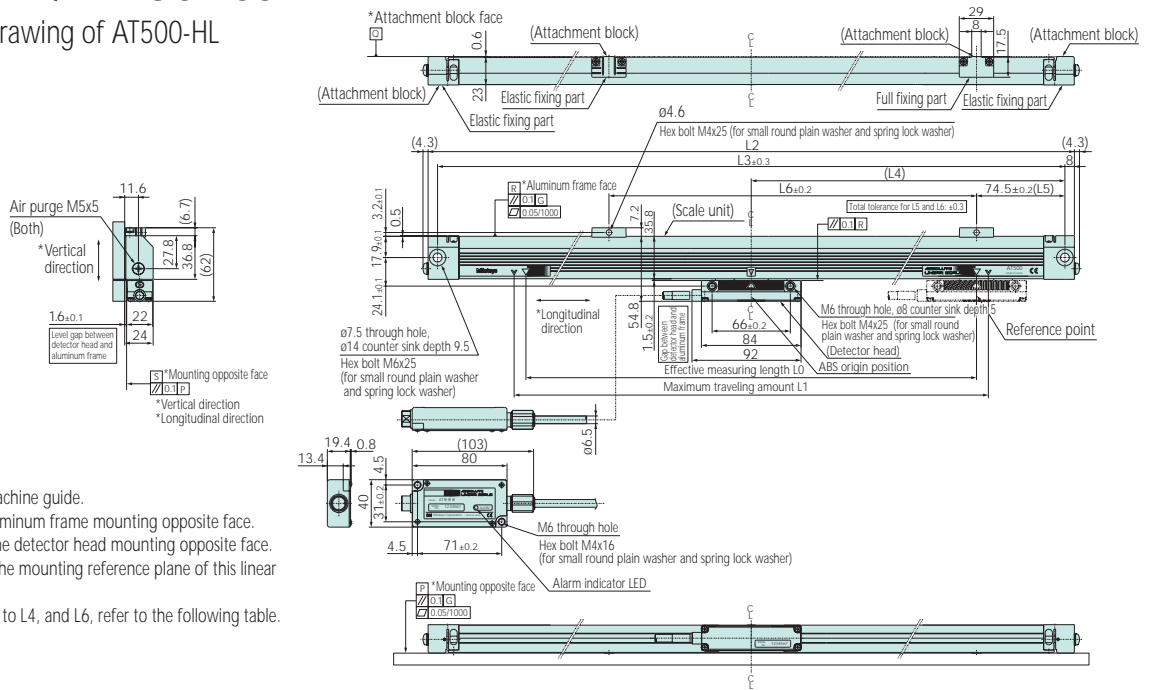

[Note]

1. G represents the machine guide.
2. P represents the aluminum frame mounting opposite face.  
Also, S represents the detector head mounting opposite face.
3. Q and R represent the mounting reference plane of this linear scale.
4. For the values of L0 to L4, and L6, refer to the following table.

Dimensional drawing of AT500-HR

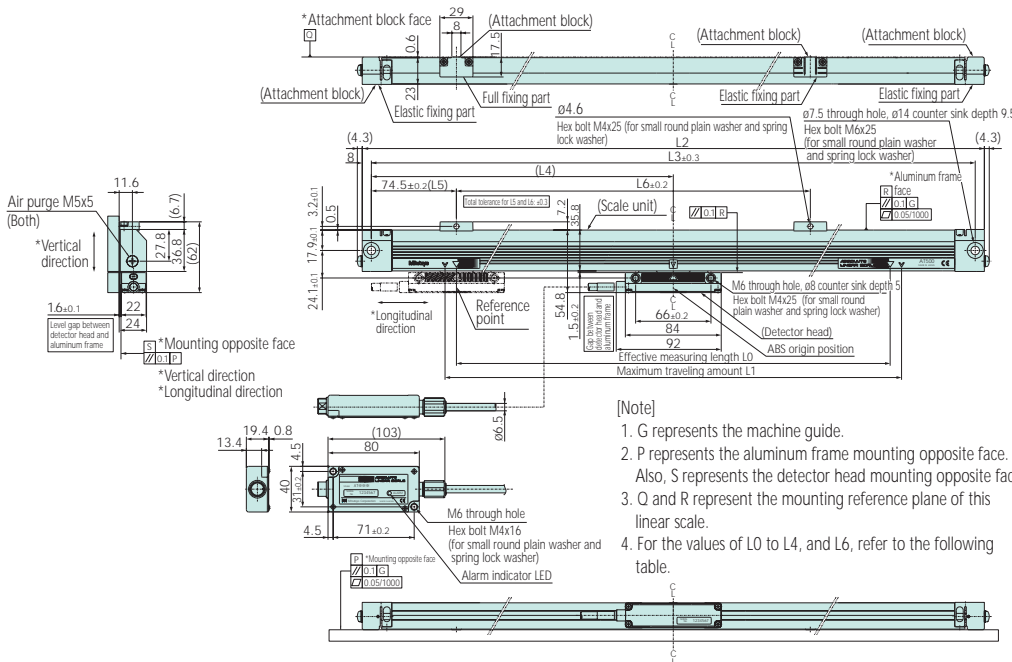

[Note]

1. G represents the machine guide.
2. P represents the aluminum frame mounting opposite face.  
Also, S represents the detector head mounting opposite face.
3. Q and R represent the mounting reference plane of this linear scale.
4. For the values of L0 to L4, and L6, refer to the following table.

Table of AT500-HL/HR Dimensions

L0	L1	L2	L3	L4	L6
100	120	265	249	124.5	-
150	170	315	299	149.5	100
200	220	365	349	174.5	130
250	270	415	399	199.5	160
300	320	465	449	224.5	190
350	370	515	499	249.5	220

(Unit: mm)

## Appearance and Dimensional Drawing

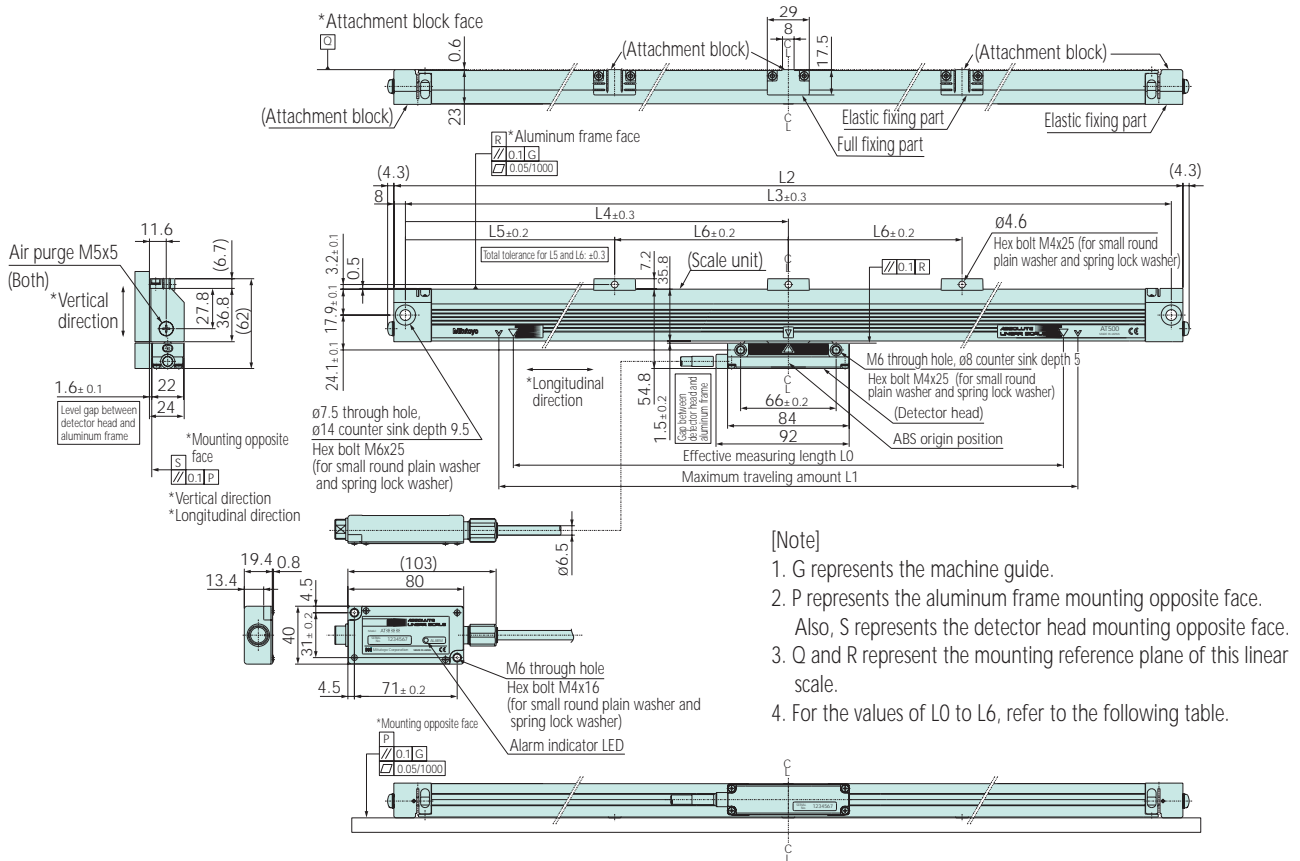

Table of AT500-HC Dimensions (Unit: mm)

$L0$	$L1$	$L2$	$L3$	$L4$	$L5$	$L6$
100	120	265	249	124.5	—	—
150	170	315	299	149.5	—	—
200	220	365	349	174.5	—	—
250	270	415	399	199.5	—	—
300	320	465	449	224.5	—	—
350	370	515	499	249.5	—	—
400	420	565	549	274.5	—	—
450	470	615	599	299.5	—	—
500	520	665	649	324.5	—	—
600	620	765	749	(374.5)	204.5	170
700	720	865	849	(424.5)	224.5	200
750	770	915	899	(449.5)	224.5	225
800	820	965	949	(474.5)	244.5	230
900	920	1065	1049	(524.5)	264.5	260
1000	1020	1165	1149	(574.5)	284.5	290

## AT500-HC Series

## Drawings of Cable Dimensions

### Lead wire type appearance and dimensional drawing

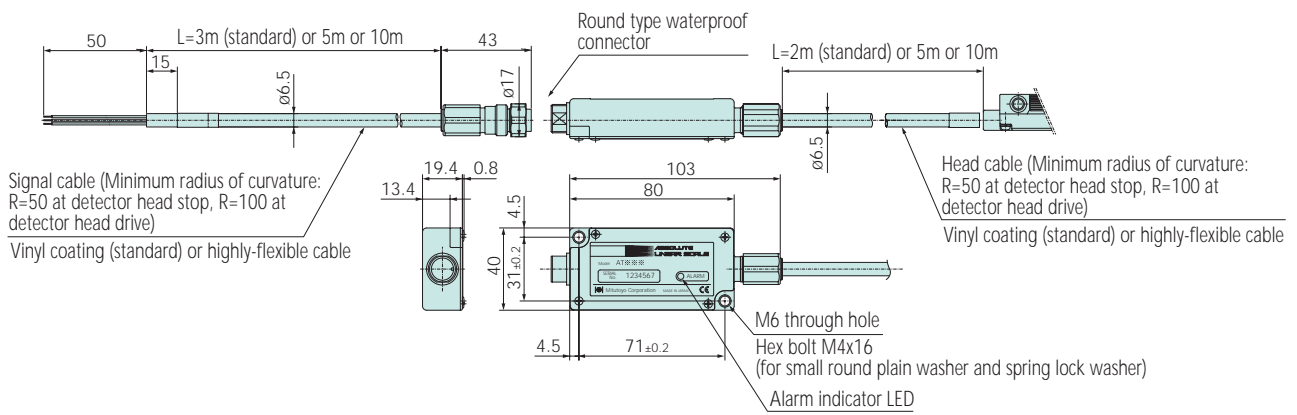

### Appearance and dimensional drawing of AT543A type

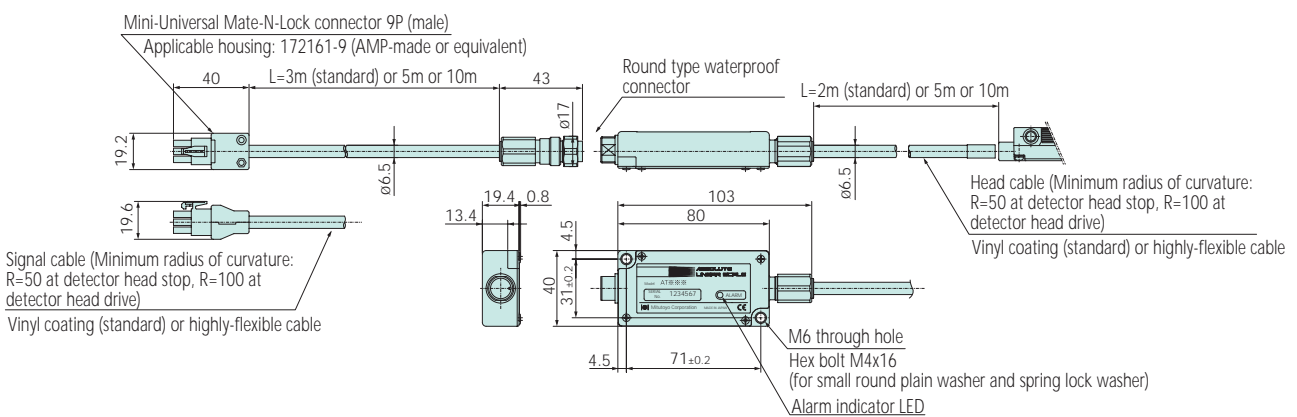



Note:  
 All our product details, in particular the illustrations, drawings, dimension and performance details and other technical specifications contained in this publication are to be considered to be approximate average values. To this extent, we reserve the right to make changes in design, technical data, dimensions and weight. Our specified standards, similar technical rules and technical specifications, descriptions and illustrations of the products are correct at the time of printing. The current version of our general terms and conditions also apply. Only offers which we have submitted can be considered to be definitive.

Coordinate Measuring Machines	11
Vision Measuring Systems	12
Form Measurement	13
Optical Measuring	14
Sensor Systems	15
Test Equipment and Seismometers	16
Digital Scale and DRO Systems	17
Small Tool Instruments and Data Management	18

**Mitutoyo Corporation**

20-1, Sakado 1-Chome,  
 Takatsu-ku, Kawasaki-shi,  
 Kanagawa 213-8533, Japan  
 T +81 (0) 44 813-8230  
 F +81 (0) 44 813-8231  
<http://www.mitutoyo.co.jp>