

High-resolution Digimatic Measuring Unit **LITEMATIC**

Catalog No. E4244-318



**Ultra-low measuring force, high accuracy
and superb resolution make an unbeatable
combination**

Mitutoyo

High accuracy & low measuring force

Litematic

Litematic
VL-50AH



Litematic
VL-50A



Mitutoyo

FEATURES Super Litematic VL-50AH

Superior precision

- Equipped with a laser hologage.
- The structural design obeys Abbe's principle to guarantee the best accuracy possible.
- The design uses low thermal expansion materials to minimize the effect of temperature variation during use.
- Newly employed smoothing effect enables stable reading.



Accuracy of 0.15 μ m (in 0 to 35mm range) is achieved!

FEATURES VL-50AH/A/AS

Patent registered (Japan), Patent pending (Japan)

Low and reliably constant measuring force

- With a measuring force of only 0.01N, the Litematic is ideal for measuring easily deformed or high-accuracy components.
- The Litematic's motor-driven spindle drives downwards until the contact point touches the workpiece, at which point the display stabilizes for reading.

Measurement with high accuracy

- Ultra-high resolution of 0.01 μ m combined with the wide measuring range of 0-50mm provides outstanding versatility.
- The measuring table is made of ceramic for rustless, easy maintainability.
- The spindle is made from a low thermal expansion material to minimize the effect of temperature variation on accuracy during use.



Litematic Head VL-50AS

SEPARATE TYPE

- The measuring unit and the display unit are separate so that they can be integrated into the user's measurement system. An optional stand is available.

Functions

Control panel/Display

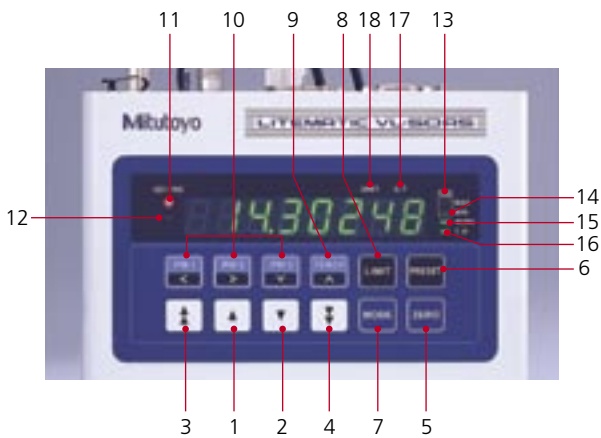

Key functions

Key	Function
1) Up	Moves the spindle up while the key is pressed. Used to retract the contact point from the workpiece after making a measurement.
2) Down	Moves the spindle down while the key is pressed. Used to bring the contact point into contact with the workpiece to make a measurement.
3) Rapid Up	Moves the spindle up rapidly while the key is pressed. Used to move quickly from one position to another.
4) Rapid Down	Moves the spindle down rapidly while the switch is pressed. Used to move quickly from one position to another.
5) ZERO	Sets the origin at the current position of the contact point and zeros all display values for runout measurements. This key can also be used to clear an error.
6) PRESET	Sets the origin at the height value entered relative to the current position of the contact point. Standard workpieces or gauge blocks are often used with this function.
7) MODE	Selects and sets one of various measurement modes such as MAX/MIN measurement.
8) LIMIT	Enters the size limits for a GO/NG tolerance judgment measurement.
9) TEACH	Sets up the position memory.
10) PM1 to PM3	Moves the spindle to an arbitrary position that has been stored with a single keystroke.

Indicator functions

Indicator	Function	
11) GO/NG	The result of a GO/NG measurement is being displayed.	
12) Sign	Indicates a minus value.	
13) MAX	Maximum value mode.	Both light when the measurement is runout type.
14) MIN	Minimum value mode.	
15) WORK	Shows that a workpiece is being measured.	
16) T.H.	Measured value is held in display after measurement has been completed.	
17) C.T.	User compensation is set to ON. (Lights while the position memory is active.)	
18) UNIT	The display value unit is inches. (Lights in the external HOLD mode.)	

Rear panel (switches and connectors)

VL-50AS/AH

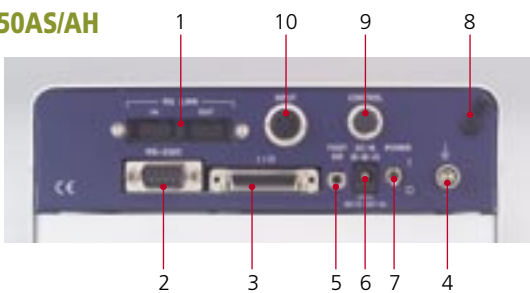

VL-50A

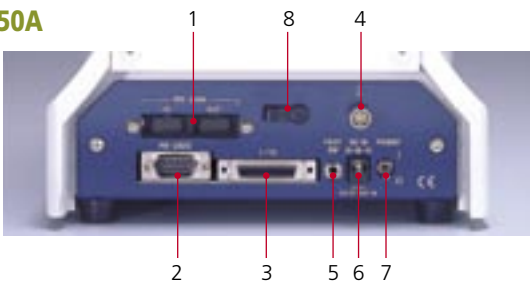

1) Measured data output connector (OUT) RS-LINK connector (IN / OUT)	Outputs measured data to a Digimatic mini-processor, etc. Connects multiple devices and can output measurement data from one RS-232 port.
2) RS-232C connector	For communication with a PC, etc.
3) External control connector	Used to connect this instrument to an external device for remote control.
4) GND terminal	—
5) Input connector for foot switch	Foot switch (optional) for controlling measurement operation is connected here.
6) DC IN	Input connector to receive power from the AC mains adapter.
7) Power switch	—
8) AC adapter cord clamp	Prevents AC adapter cord from pulling out.
9) CONTROL connector: for VL-50AS only	Gage head connector.
10) INPUT connector: for VL-50AS only	Gage head connector.

RS-232C Communication Function

RS232C output enables PC data processing of measurement data. SENSORPAK (data capture software) provides an analog meter display of the current measurement and a magnified display of OK/NG results. It also enables measurement data to be entered directly from the keyboard.

Direct data entry to EXCEL

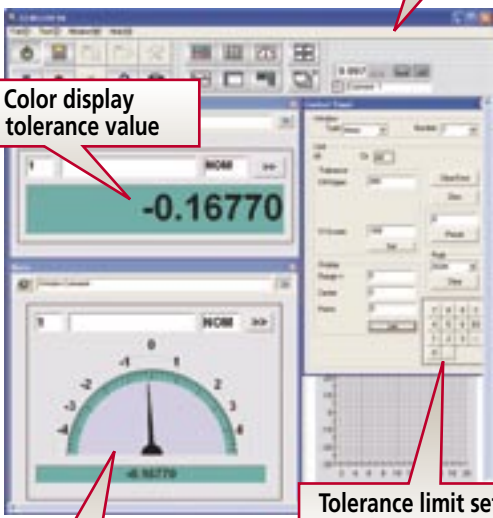

Color display of tolerance value

Easily readable meter indication

Tolerance limit setting with PC is possible

Operating environment

- CPU: 2GHz2 or more is recommended
- OS: Windows 2000/ XP (Excel 2000/XP)
- RS-232C cable: Crossing cable type



RS-232C

Connector terminal Function

Remote control by external signals is possible.

Applicable plug: No. 02ADB440
(with cover) Optional accessory

Pin assignment

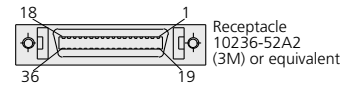

Pin No.	Signal name	Input/Output	Description (purpose)																		
1	COM	—	Common terminal to input and output circuits (internally connected to GND)																		
2	COM	—																			
3	L1	OUT	Tolerance judgment output terminal																		
4	L2	OUT	A related judgment terminal only outputs "L" At error occurrence																		
5	L3	OUT	L1, L5: Outputs "L"																		
6	L4	OUT	L2, L3, L4: Outputs "H"																		
7	L5	OUT																			
10	NOM	OUT	Outputs "L" in the count mode.																		
21	ULIMIT	OUT	Outputs "L" at the topmost travel point of the spindle																		
22	WORK	OUT	Outputs "L" upon detection of a workpiece.																		
25	SET1	IN	Specifies peak selection/motor speed in combination with SET.																		
26	SET2	IN																			
28	MODE	IN	Peak selection: In combination with SET. <table border="1" style="font-size: small;"> <tr> <td>Peak Mode</td> <td>SET2</td> <td>SET1</td> </tr> <tr> <td>Current value</td> <td>H</td> <td>H</td> </tr> <tr> <td>MAX</td> <td>H</td> <td>L</td> </tr> <tr> <td>MIN</td> <td>L</td> <td>H</td> </tr> <tr> <td>TIR</td> <td>L</td> <td>L</td> </tr> </table>	Peak Mode	SET2	SET1	Current value	H	H	MAX	H	L	MIN	L	H	TIR	L	L			
Peak Mode	SET2	SET1																			
Current value	H	H																			
MAX	H	L																			
MIN	L	H																			
TIR	L	L																			
30	UP	IN	Motor control: Specifies a spindle ascent speed along with SET. <table border="1" style="font-size: small;"> <tr> <td>Speed</td> <td>SET2</td> <td>SET1</td> </tr> <tr> <td>VL-50AH VL-50A/AS</td> <td>H</td> <td>H</td> </tr> <tr> <td>5mm/s</td> <td>8mm/s</td> <td>H</td> </tr> <tr> <td>3mm/s</td> <td>4mm/s</td> <td>H</td> </tr> <tr> <td>2mm/s</td> <td>2mm/s</td> <td>L</td> </tr> <tr> <td>1mm/s</td> <td>1mm/s</td> <td>L</td> </tr> </table> When changing the spindle speed, stops the spindle once and allows 50ms or more before change.	Speed	SET2	SET1	VL-50AH VL-50A/AS	H	H	5mm/s	8mm/s	H	3mm/s	4mm/s	H	2mm/s	2mm/s	L	1mm/s	1mm/s	L
Speed	SET2	SET1																			
VL-50AH VL-50A/AS	H	H																			
5mm/s	8mm/s	H																			
3mm/s	4mm/s	H																			
2mm/s	2mm/s	L																			
1mm/s	1mm/s	L																			
31	DN	IN	Motor control: Specifies a spindle descent speed along with SET. <table border="1" style="font-size: small;"> <tr> <td>Speed</td> <td>SET2</td> <td>SET1</td> </tr> <tr> <td>VL-50AH VL-50A/AS</td> <td>H</td> <td>H</td> </tr> <tr> <td>5mm/s</td> <td>8mm/s</td> <td>H</td> </tr> <tr> <td>3mm/s</td> <td>4mm/s</td> <td>H</td> </tr> <tr> <td>2mm/s</td> <td>2mm/s</td> <td>L</td> </tr> <tr> <td>1mm/s</td> <td>1mm/s</td> <td>L</td> </tr> </table> When changing the spindle speed, stops the spindle once and allows 50ms or more before change.	Speed	SET2	SET1	VL-50AH VL-50A/AS	H	H	5mm/s	8mm/s	H	3mm/s	4mm/s	H	2mm/s	2mm/s	L	1mm/s	1mm/s	L
Speed	SET2	SET1																			
VL-50AH VL-50A/AS	H	H																			
5mm/s	8mm/s	H																			
3mm/s	4mm/s	H																			
2mm/s	2mm/s	L																			
1mm/s	1mm/s	L																			
32	FSW	IN	Motor control: Same function as that of the foot switch.																		
34	HOLD	IN	The display value is held during input. An error is cleared at the leading edge of this signal.																		
35	P.SET	IN	Executes presetting. Peak clear: The peak value is cleared upon input of the signal during the HOLD signal input in the Peak mode.																		
	N.C.	—	Unconnected terminals (8, 9, 11, to 20, 23, 24, 27, 29, 33 and 36 pin terminals)																		

Digimatic output function

Printer

Digimatic mini processor DP-1VR
No. 264-504
Prints the digimatic output from Litematic. Connecting cable 1m (No. 936937)



Data transmission to the PC

Input Tool IT-005D
No. 264-005 (for Serial/keyboard port)

Input Tool IT-012U
No. 264-012 (for USB port)
Converts the digimatic output from Litematic into keyboard signals and transfers to the PC. Connecting cable 1m (No. 936937)



Measuring examples



Diameter of resin pipe

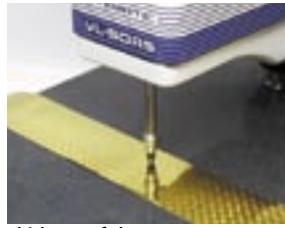

Thickness of sheet

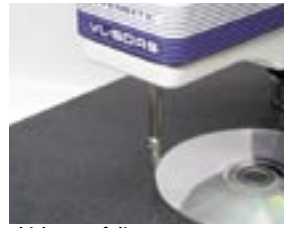

Thickness of disc



Contour of lens



Thickness of dried noodle



Dimension of machine part

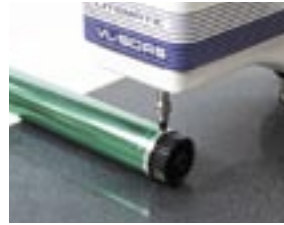

Diameter of photosensitive drum



Thickness of urethane foam



Height of resin container



Height of spacer



Dimension of resin part



Thickness of rubber strip



Dimension of dust-proof cap



Thickness of gasket

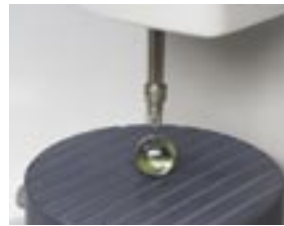

Diameter of glass sphere



Diameter of light bulb



Diameter of ceramics



Dimension of pill



Dimension of machine part



Diameter of precision shaft



Diameter of bearing



Diameter of carbide ball



Contour of blade tip



Depth of key groove

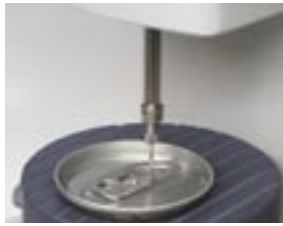

Pressed contour of can lid

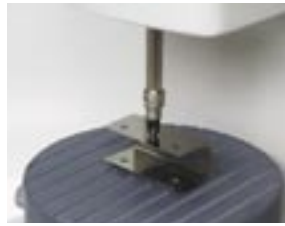

Dimension of sheet metal



Height of connector pin



Dimension of electronic part

Dimensions

Litematic VL-50AH

Unit: mm

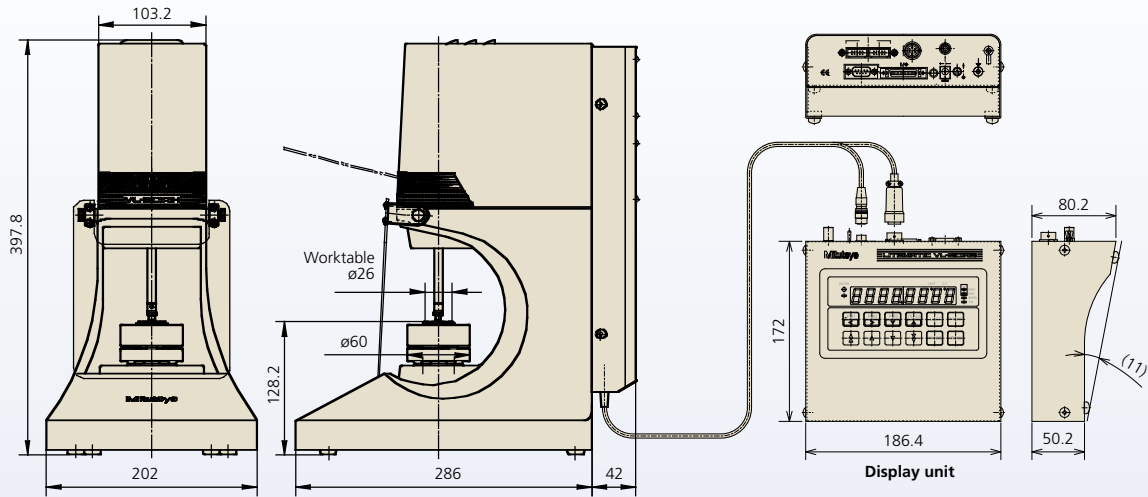

Litematic VL-50A

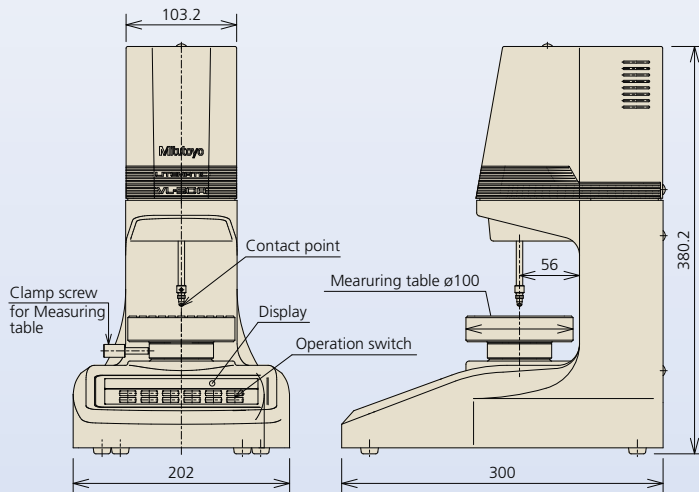

Interchangeable contact points

Unit: mm

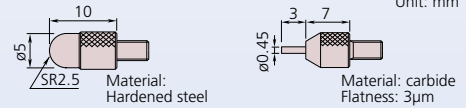

Material: Hardened steel

Material: carbide
Flatness: 3µm

Order No.	Measuring force
101118	0.02N

Order No.	Measuring force
120066	0.01N

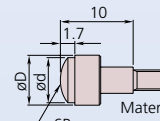

Material: carbide

Order No.	Measuring force	D	d	SR
120059	0.03N	ø7.5	ø6.5	7
120060	0.06N	ø10.5	ø9.5	10

Litematic Head VL-50AS

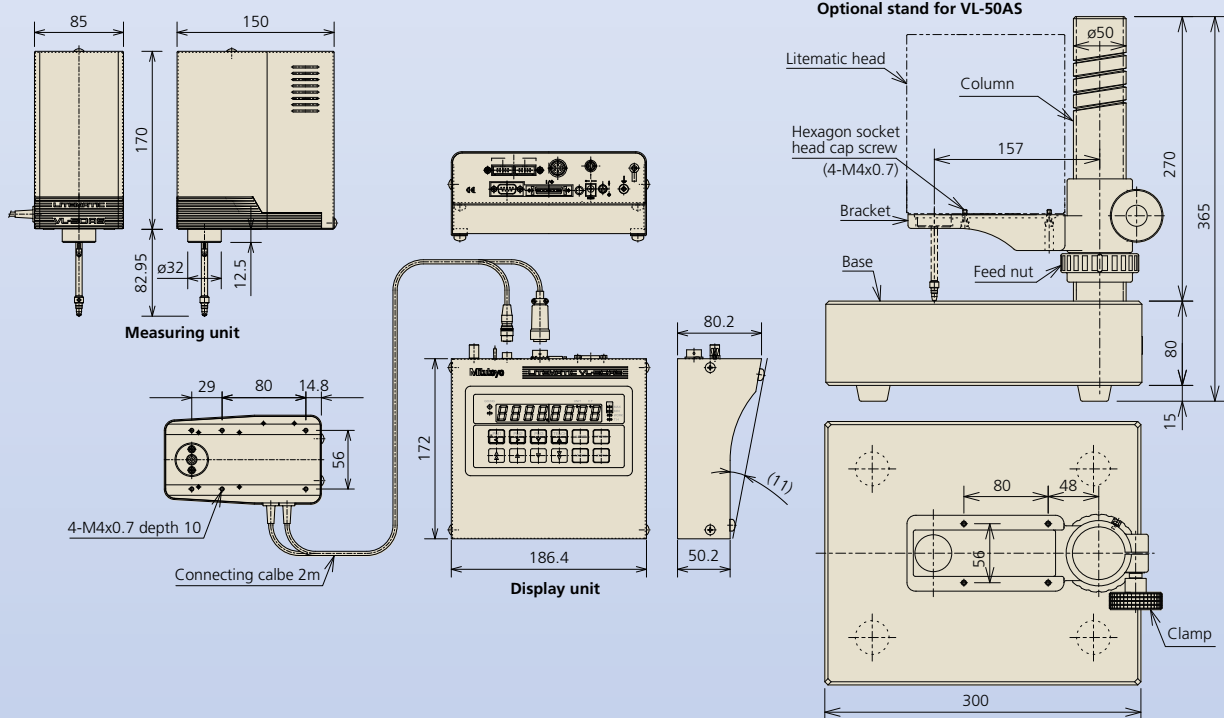

SPECIFICATIONS

Model	VL-50AH	VL-50A	VL-50AS
Order No.	318-217	318-211	318-213
Measuring Range*	0 - 50mm (0 - 2")		
Resolution (selectable)	0.01µm/0.1µm/1.0µm (.0000005"/.000005"/.00005")		
Display unit	Character height 14mm (.6") / 8 digits (excluding " -" sign)		
Stroke*	51.5mm (2")		
Accuracy at 20°C*	0.15µm: 0-35mm 0.25µm: 35-50mm	(0.5+L/100)µm L=Measured length (mm)	
Accuracy guarantee temperature**	20±0.5°C	20±1°C	
Repeatability*	σ=0.02µm	σ=0.05µm	
Measuring force*	0.01N		
Spindle feed speed	Measuring	Approx. 1mm/s (.04"/s) / 2mm/s (.08"/s)/3mm/s (.12"/s)	Approx. 2mm/s (.08"/s) or 4mm/s (.16"/s)
	Rapid feed	Approx. 5mm/s	Approx. 8mm/s (.3"/s)
Contact point	R5 carbide ball	Ø3mm carbide ball	
Worktable	Ø26mm ceramic (grooved)	Ø100mm ceramic (grooved replaceable)	—
Data Input	Data can be input with the foot switch		
Output	Via SDP/RS-232C		
Power supply	85-264V AC		
Power consumption	12W max		
Mass	21kg	19kg (35.2 lbs)	6kg (11 lbs)
Standard accessories	AC adapter No. 357651 Power code: (depends on the power supply used), Ground wire Allen wrench		
Optional accessories	Foot switch No. 937179T		
	—	—	Dedicated stand No. 957460
	RS-LINK/Digimatic connecting cable (1m) No. 936937		
RS-LINK/Digimatic connecting cable (2m) No. 965014			

Note : To denote your AC line voltage add the following suffixes (e.g. **318-211A**). **A** for 120V, **C** for 110V, **D** for 220V, **E** for 240V, No suffix is required for 100V

* Applies for normal measurement with the standard contact point

** Temperature variation must be moderate. The instrument must not be exposed to direct draughts.

Specifications are subject to change without notice.

Note: All information regarding our products, and in particular the illustrations, drawings, dimensional and performance data contained in this pamphlet, as well as other technical data are to be regarded as approximate average values. We therefore reserve the right to make changes to the corresponding designs, dimensions and weights. The stated standards, similar technical regulations, descriptions and illustrations of the products were valid at the time of printing. In addition, the latest applicable version of our General Trading Conditions will apply. Only quotations submitted by ourselves may be regarded as definitive.

Coordinate Measuring Machines

Vision Measuring Systems

Form Measurement

Optical Measuring

Sensor Systems

Test Equipment and
Seismometer

Digital Scale and DRO Systems

Small Tool Instruments and
Data Management

Mitutoyo Corporation

20-1, Sakado 1-Chome,
Takatsu-ku, Kawasaki-shi,
Kanagawa 213-8533, Japan
T +81 (0) 44 813-8230
F +81 (0) 44 813-8231
<http://www.mitutoyo.co.jp>

Mitutoyo